

Externally Heated

Exhaust Purge

Regenerative Compressed Air Dryer



Henderson Engineering Co.
815.786.9471 800.544.4379

Provides safety and reliability

Designed for medium flow rates

Conservative design for optimal energy efficiency and savings



World Leader in Regenerative Dryer Technology





World Leader in Regenerative Dryer Technology



Henderson Engineering Co.
815.786.9471 800.544.4379

Energy Saver

Simple and efficient, the externally heated EP is the safest and most trouble-free of any heat reactivated regenerative type air dryer

Designed for medium flow rates, the Sahara Exhaust Purge dryer provides great flexibility. A twin tower dryer that delivers dry air with a -40°F / -40°C pressure dew point, Sahara's EP delivers a dew point even lower than required by the Instrument Society of America.

The conservative design, developed for optimal energy savings with roughly twice the amount of desiccant required to dry air at full design water load, assures years of superior performance before desiccant replacement is required.



A Long & Proud Company History



Sahara Air Products, a Division of Henderson Engineering Co., Inc., was founded in 1957 by Joe and Evelyn Henderson to provide engineered solutions for air system problems. Mr. Henderson's philosophy was to thoroughly examine the unique requirements of each customer and to develop the most economical and reliable system solution for that application. This trademark of engineered solutions exists at Sahara today, as the third generation of Hendersons continue the tradition of product excellence and customer service. Sahara's reputation for high quality, innovative products, and customer loyalty has continued to grow through the years.

As a family business, we know that our greatest assets are our employees. Most of our people have been with us for more than 20 years. There is no substitute for experience. Sahara employees are true team members who know what they're doing and they truly care about doing it right the first time. This means you get what you want; a drying system that delivers performance year after year, decade after decade.

Quality and old world craftsmanship never goes out of style

Custom Design

Dryers are purchased to solve plant air problems. The decision to buy is complex and involves many variables; initial price, vendor qualifications, delivery, performance, and operating cost, just to name a few. The selection of a SAHARA air dryer is a safe choice. Our sales engineers will help you select the right system for your application. They have the expertise to review your plant air system and design the optimum engineered solution.

Need your documentation and instruction manuals in your native language? Require instrumentation in dual scale? With Sahara's experience in designing and building our products for customers worldwide, we can provide that for you.

Applications

- We make dryers for instrument air, as well as a variety of special applications
- High pressure up to 5000 PSIG / 345 Bar(g)
- Low pressure down to 20 PSIG / 1.4 Bar(g) for ozone generators that deliver constant, flat line, not to exceed -100°F / -73°C dew points
- Gases other than air; N₂, CO₂, CH₄
- We build dryers to API specifications
- We also make dryers for air separation companies
- Capable of delivering extremely low dew points
- Used in automotive paint applications or electronics where air is used to blanket chips and for any critical uses that demand dry air

We can build a dryer to meet your strict performance requirements

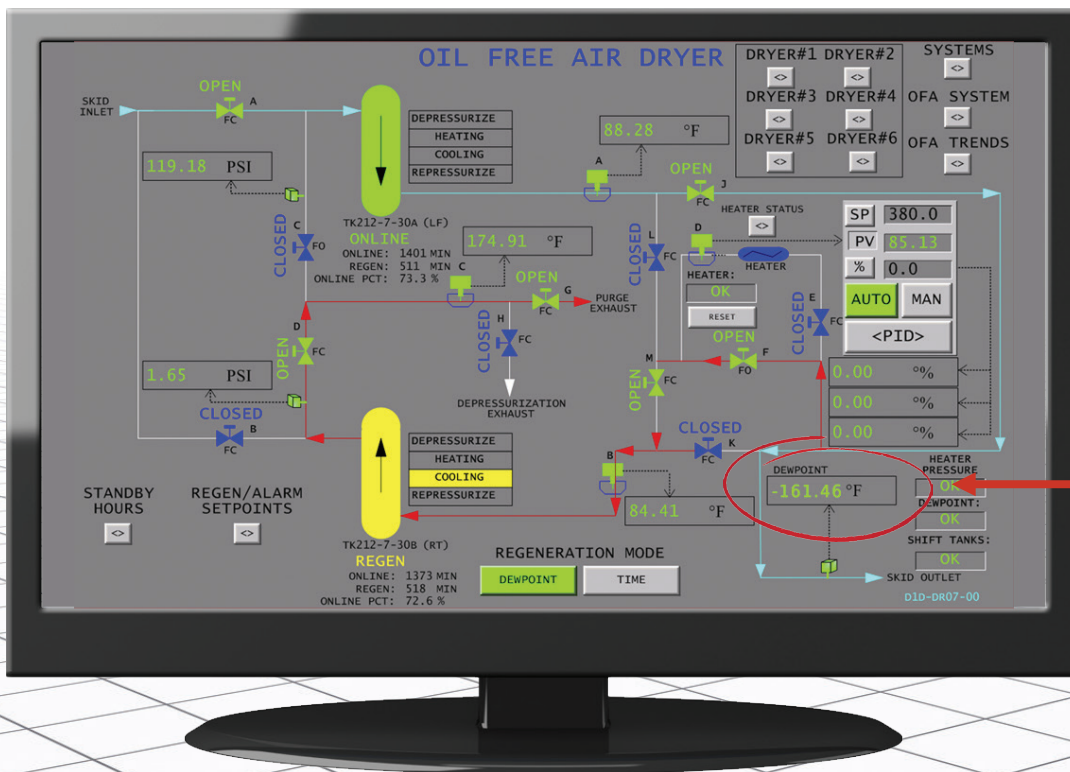

-161.46 PDP
at one of our
electronics
customer's facilities

**Quality and reliability are built into every SAHARA air dryer
and performance is guaranteed**



World Leader in Regenerative Dryer Technology



Henderson Engineering Co.
815.786.9471 800.544.4379

Controller Comes Standard

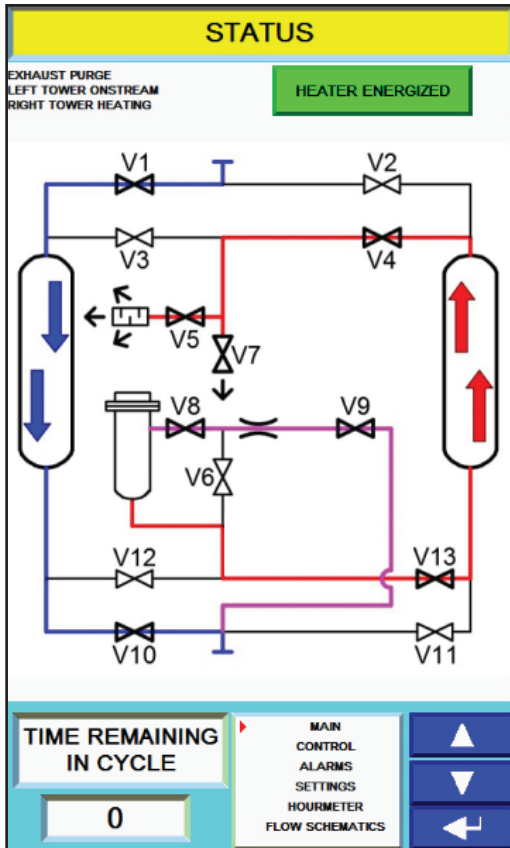

- The standard **PLC is the Allen-Bradley Micrologix 1400** with individual input/output modules which controls the dryer's operation
- Ethernet communication
- The controller's standard **operator interface is the Allen-Bradley PanelView 800**
- Housed in a NEMA 1 enclosure, the operator interface uses a touch sensitive screen with control functions performed by touching on-screen display buttons to change screens, modify settings, or enter values
- Dryer cycle indication
- P&ID for each cycle on operator interface screen



Henderson Engineering Co.
815-786-9471 800-544-4379
www.saharahenderson.com

Benefits

All products are a combination of basic design philosophy and selection of components. The Sahara Exhaust Purge dryer uses a basic design of convection heating to regenerate the desiccant. We heat the purge air and allow the hot air to gently transfer heat to the desiccant. The other possible method of regeneration is called conduction; a design that uses multiple heater tubes throughout the desiccant bed generating extremely high temperatures at each heater hoping that the desiccant will conduct heat from bead to bead. The problem is that desiccant is a good insulator and a poor conductor, so to transfer heat the heating elements must reach temperatures in excess of 1000°F. This leads to premature desiccant life, heater failures and even heater fires.

Convection heating is a much safer, more reliable basic design.

Proper selection of components is perhaps the most important job of the design engineer. It's easy to look for the cheapest parts and hope that everything lasts through the warranty period. We don't do that; we design our dryers to operate for years without failures.

Heaters are incoloy sheathed and derated to 14 watts/sq in. This is an exceptionally conservative design which means the heater doesn't get as hot and reduces the risk of a heater failure.

We control our heater with several controls; a dual set point indicating temperature controller is the primary control that regulates the discharge temperature of the heater. It has 2 set points so if one fails then the secondary set point shuts the heater down and prevents high temperatures. Additionally; we install another controller in the inlet or cold zone of the heater as a triple redundant safety back up. If for any reason purge flow is restricted or shut off then heat will not reach the primary control and the outlet, so the cold zone controller shuts the heater down and prevents a heater failure.

All dryers are basically tanks and valves. Check valves are inexpensive and may operate for a period of time, but ultimately will fail. High performance switching valves are more expensive, but will operate reliably for years. We use only high performance switching valves. Butterfly valves that are fire safe and leak tight. Sure it costs more, but how much does a dryer failure cost?

The Sahara design philosophy and choice of components insure a safe, reliable heated dryer that performs year after year.

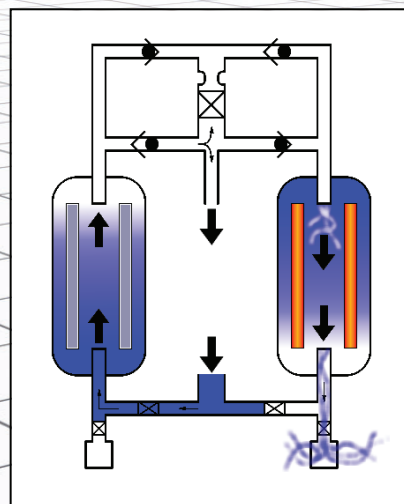

Internal Heat Conduction

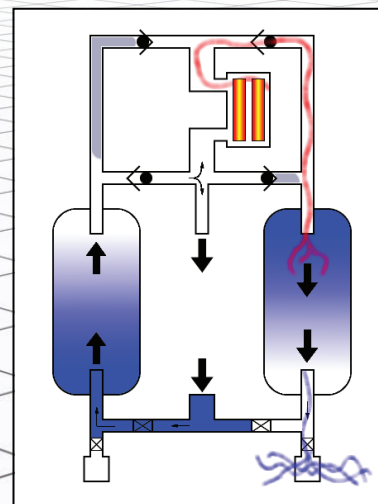

External Heat Conduction



World Leader in Regenerative Dryer Technology



Henderson Engineering Co.
815.786.9471 800.544.4379



LOW PRESSURE DROP

Complete system designed to keep pressure drop low.

- The pressure drop is calculated at <3 PSID.

CONTROLLED BLOWDOWN

To prevent shocking or fluidization of the desiccant, separate depressurization and purge exhaust valves are used. Controlled depressurization occurs before opening the purge exhaust valve for regeneration.

EASE OF MAINTENANCE

Where necessary, when valves are mounted between towers, instead of welding both towers to the structural steel base, we weld one and BOLT the other tower. Valve maintenance is made much simpler by being able to remove one tower.

Quality Integral Components & Features

SWITCHING VALVES



- Reliable 2-way non-lubricated
- Directs air to the drying tower
- 2" & smaller are 2-way rack and pinion actuated bronze ball valves
- 3" & larger are high performance butterfly valves w/SS internals and reinforced teflon seat

ELECTRICAL



- Housed in a NEMA 1 enclosure
- Built to latest NEC Guidelines

ELECTRIC HEATER



- Derated to a maximum of 14 watts/sq. in. density for longer life
- Inconel sheathed
- Heating elements not in direct contact with desiccant

PRESSURE SWITCH



- Controls purge exhaust valve
- Prevents heater from being energized until tower is depressurized
- Prevents catastrophic air loss in the event of valve failure (EP-490 and larger)

DEPRESSURIZATION MUFFLERS



- Utilized on the blowdown, keeps noise levels to a minimum
- Complies with OSHA standards by keeping noise tolerance at <85 dBA on a time-weighted average

PUCK STYLE TEMPERATURE TRANSMITTER



- For heater control & cold zone
- Transmitter regulates heater outlet temperature
- Temperature indication and alarms displayed on PanelView screen
- A separate transmitter located in the cold zone of the heater provides additional protection, in case of low or lost flow
- A third temperature transmitter for the purge exhaust to monitor bed regen temperature

SEPARATE PILOT AIR FILTER



- With pressure gauge and block valve to protect dryer control system



World Leader in Regenerative Dryer Technology



Henderson Engineering Co.
815.786.9471 800.544.4379

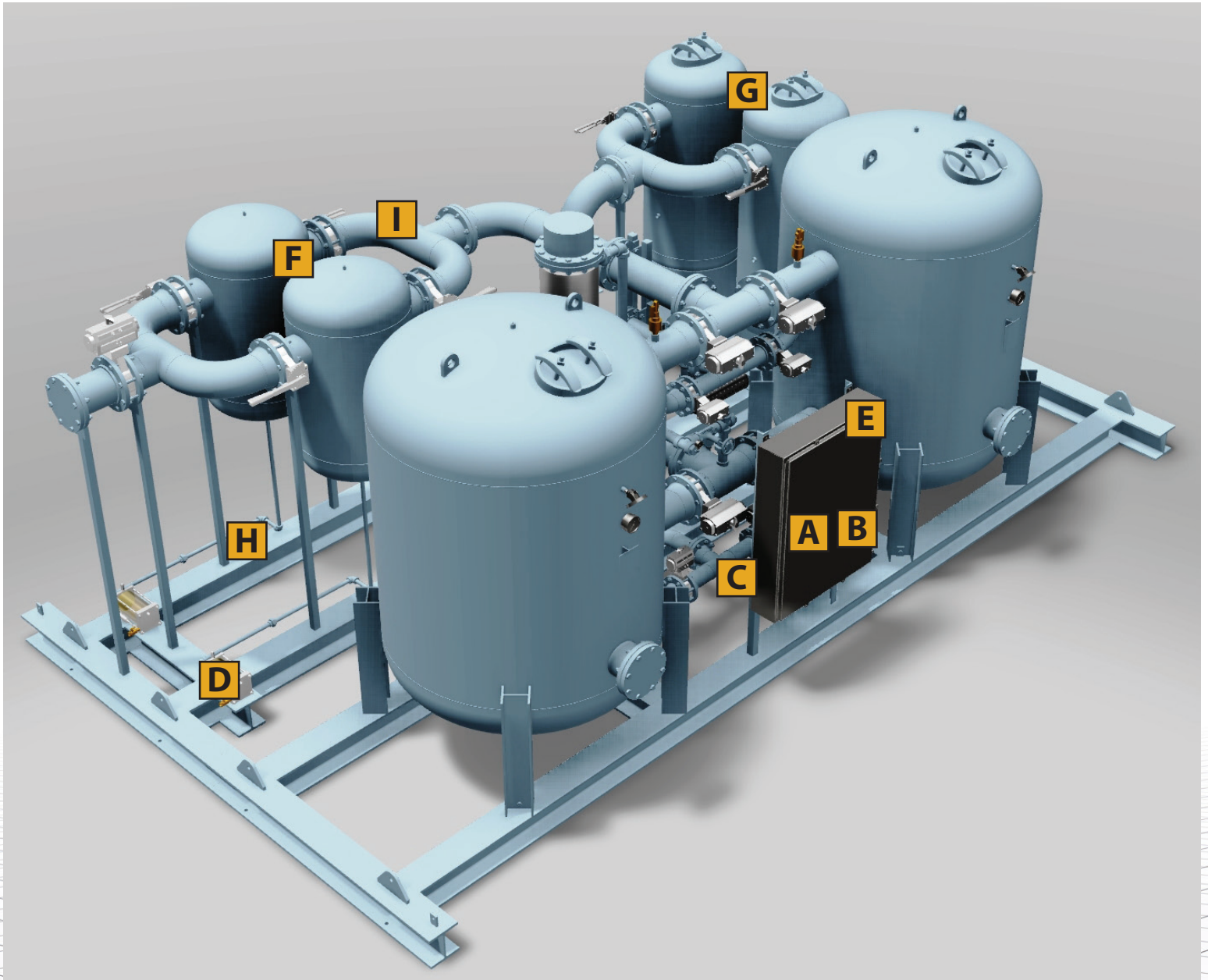

Other options available.

*We can custom build a dryer to meet your strict performance requirements.
Contact us and our sales engineers will help you select
the right system for your application.*

Standard Options

A SAHARA DEW POINT DEMAND SYSTEM

Energy conservation has always been a strong design consideration of Sahara Air Products. The Dew Point Demand System measures the dew point of the outlet air, overriding the timer, eliminating unnecessary switching of towers resulting in considerable savings through reduction of regeneration cost. Additional savings can be realized with this system by reducing wear on component parts, as well as extending the life of desiccant.

The SAHARA Dew Point Demand System utilizes a state-of-the-art moisture transmitter to accurately measure the actual PRESSURE DEW POINT the dryer is delivering at all times. The instrument reads directly to the PLC and is displayed on the Panel View screen, which constantly keeps you informed of dryer performance. An adjustable set point allows you to set the precise dew point for tower switching. Tower switching can be activated anywhere within the broad range of -148°F to +86°F.

B FAIL-TO-SHIFT ALARM INDICATION

Indication that malfunction has occurred, preventing towers from shifting at the proper time or dew point sequence.

C MOISTURE INDICATOR

Visual indication of outlet air moisture content by means of color change media.

D DRAIN TRAP

We recommend utilizing a drain trap on each coalescing prefilter.

E NEMA 4, 7, or 12 ELECTRICAL CONSTRUCTION

F COALESCING PREFILTER

For optimum performance of a regenerative dryer application, we recommend a prefilter upstream of the dryer to protect the desiccant bed from contamination by oil, entrained water, or other contaminants. For this duty, we offer a Sahara high efficiency oil coalescing prefilter (HEF). This unit is constructed of carbon steel to ASME standards and is designed to filter oil to 1 PPM and dirt particles to 0.3 micron with a 75 PSIG differential collapse pressure.

G HIGH TEMPERATURE PARTICULATE AFTERFILTER

We recommend an afterfilter downstream of the dryer to eliminate the possibility of desiccant dust carryover into the air system. For this duty, we offer a Sahara high temperature particulate afterfilter (HAF). This unit is constructed of carbon steel to ASME standards and the elements are designed to filter particles to 0.9 micron.

H FILTER MOUNTING

Filters may be mounted on dryer skid for ease of installation.

I ISOLATION & BYPASS PIPING

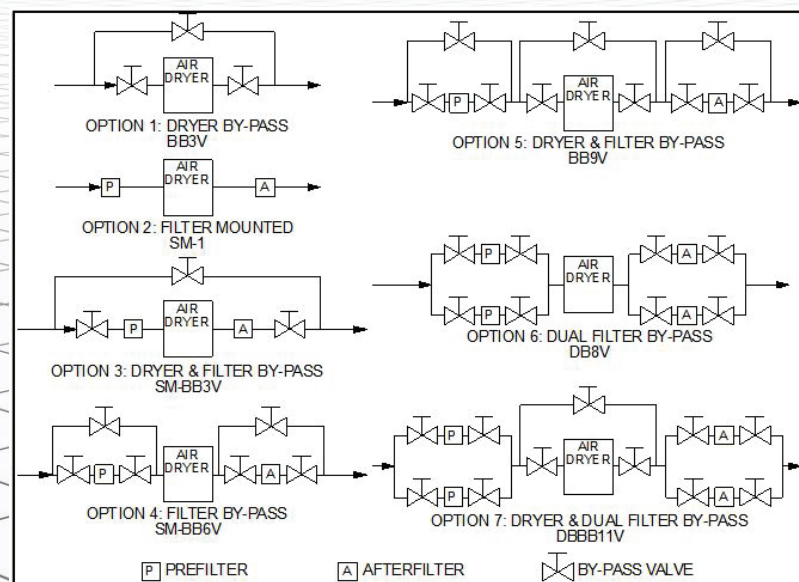



World Leader in Regenerative Dryer Technology



Henderson Engineering Co.
815.786.9471 800.544.4379

Theory of Operation

While the desiccant in one tower is onstream drying the air, the desiccant in the other tower is offstream being regenerated. The two towers are linked using switching valves, so that when the desiccant in the drying tower is saturated, the valves switch the flow into the tower that's just been regenerated. Because the towers alternate, the air stream is always exposed to dry desiccant.

DEPRESSURIZATION/REGENERATION

Initially, the offline tower is depressurized, to close to ambient pressure. Dry air is expanded to atmospheric pressure where 7% of the dry air is diverted into the heater where it is heated and diverted into the regenerating tower. This hot dry air comes into equilibrium with the desiccant and regenerates it back to full capacity. The wet air is then exhausted to atmosphere.

HEATING

7% of model selection is used to regenerate the bed. This air is taken from downstream of the dryer at low dew point and is heated to 375°F / 190.56°C for 3 hours. The use of this hot thirsty air is used to remove moisture from the saturated desiccant.

COOLING

After heating, the heater is turned off and the dry purge air is now used to cool the desiccant in a one hour cooling cycle. This minimizes temperature or dew point bumps at tower shift.

REPRESSURIZATION/DRYING

After cooling, the regenerating tower is slowly pressurized up to operating pressure. Then, valves are switched to bring the regenerating tower to the drying position in the cycle. Because we use a full 7% purge rate during the cooling cycle and bypass the heater during cooling (on EP-560's and larger), we reduce the temperature and dew-point spike that occurs with competitive low purge flow, heat-reactivated dryers.

STANDBY

This regeneration cycle will be continuous, unless equipped with the Sahara Dew Point Demand System. In models equipped with the Dewpoint Demand System, a moisture transmitter senses desiccant saturation, overrides the timer, and extends the drying cycle. This saves the user operational energy costs, as well as wear and tear on mechanical components and maintenance.

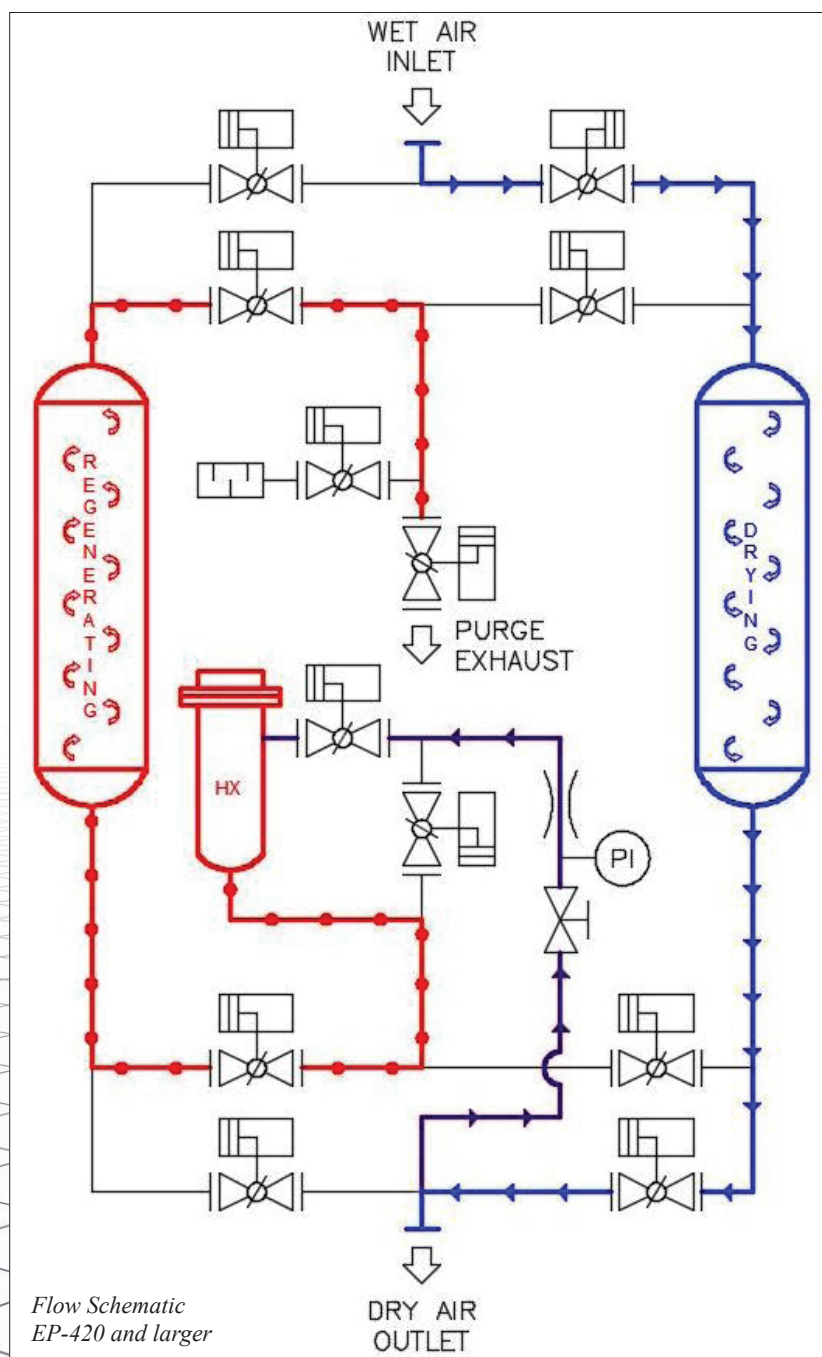

Flow Schematic
EP-420 and larger

Safe & Reliable

Sahara's EP design stresses safety and reliability, eliminating the possibility of heater burnout and, more importantly, safeguards against catastrophic heater fire by implementing backup systems.



The use of an external heater eliminates the problems associated with internal heat-reactivated dryers. The externally mounted heater is not in contact with the desiccant which increases the desiccant life. In addition, the inconel-sheathed heater is derated to 14 watts/sq. in., virtually eliminating the possibility of heater burnout.

The heater is controlled by a dual setpoint digital temperature controller, with additional protection provided by a thermostat located in the heater's cold zone.

Worldwide Installations



Glass & Plastics Producers

Electric & Power Utilities

Breweries

Waste Management

Automotive & Airline Industry

Recycling

Diagnostics

Oil Refineries

Nuclear Energy

Electronics

Chemical Companies

Fabricators

Paint Manufacturers

Healthcare

Aluminum & Steel Foundries



World Leader in Regenerative Dryer Technology



Henderson Engineering Co.
815.786.9471 800.544.4379

Specifications

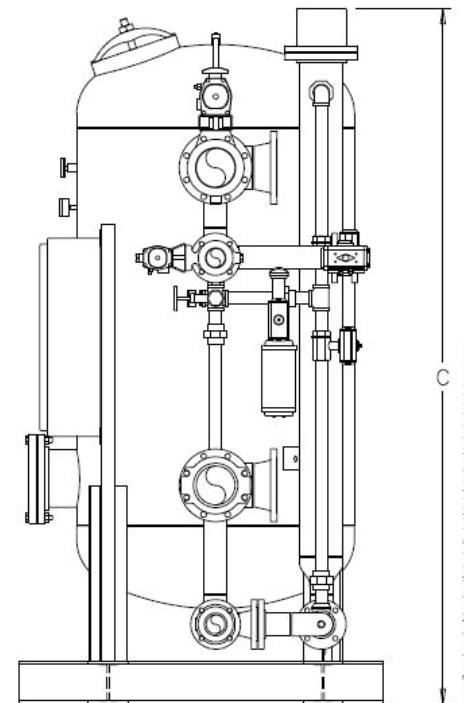
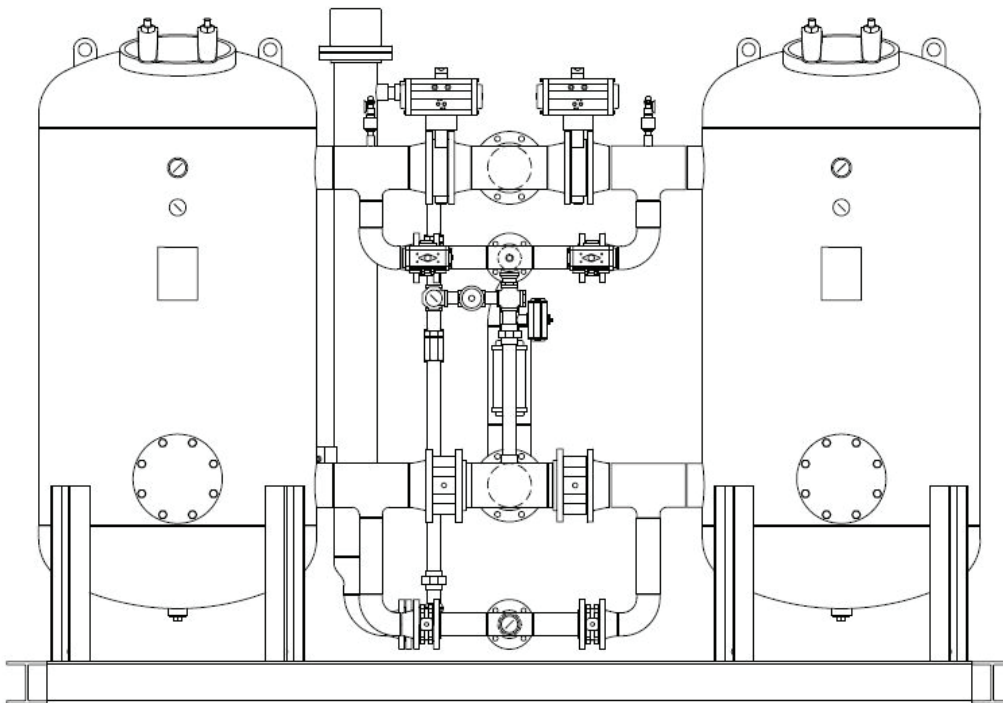
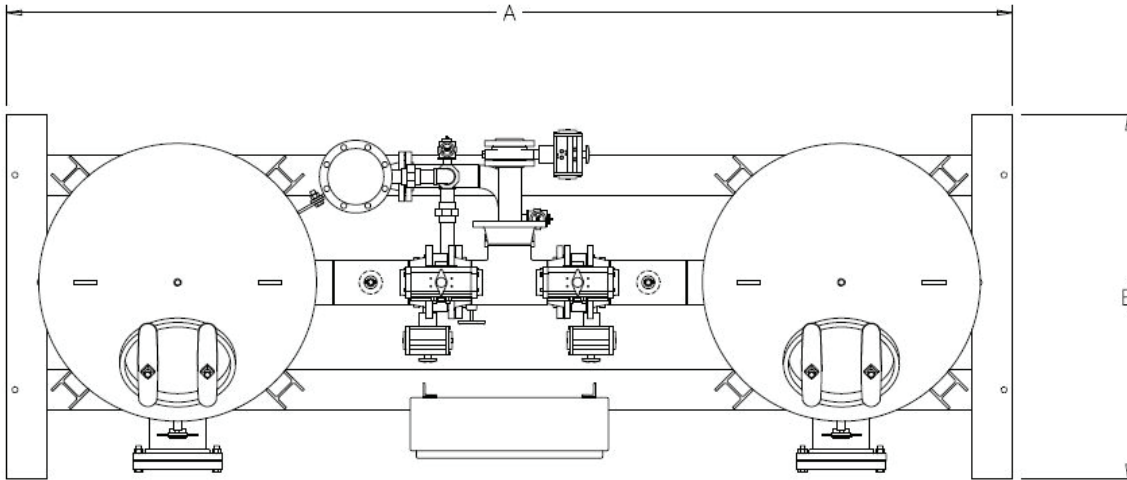

EP-420 and larger

Exhaust Purge Regenerative Compressed Air Dryer

Model	Rated Flow (SCFM)	A = Length (Inches)	B = Width (Inches)	C = Height (Inches)	Approx. Weight (Lbs.)	Conn. Size (Inches)	Purge Rate (SCFM)	Desiccant per Tower (Lbs.)	Heater Size (KW)	Avg. Power (KWH/24 Hrs.)
EP-7	7	28	8	24	186	1/4	.5	4	.5	0.77
EP-14	14	28	8	26	197	1/4	1	8	.5	1.54
EP-35	35	45	12	42	384	1/2	2.5	20	.5	3.84
EP-56	56	45	12	42	486	1/2	3.9	32	.5	6.14
EP-70	70	58	25	63	486	3/4	4.9	40	1	7.68
EP-100	100	62	33	63	621	1	7.0	60	1	10.97
EP-140	140	62	33	63	675	1	10	80	2	15.35
EP-210	210	55	38	63	749	1 1/2	15	120	2	23.03
EP-280	280	55	38	63	1097	1 1/2	20	160	3	30.71
EP-350	350	66	45	75	1242	2	25	200	3	38.39
EP-420	420	66	45	75	1350	2	29	240	4	46.06
EP-490	490	69	44	74	1566	2	35	280	4	53.74
EP-560	560	69	44	74	1782	2	40	320	5	61.42
EP-630	630	82	46	77	2052	3	45	360	5	69.1
EP-700	700	82	46	92	2160	3	49	400	7.5	76.77
EP-770	770	95	46	96	2687	3	54	440	7.5	84.45
EP-840	840	95	46	96	2794	3	59	480	7.5	92.13
EP-980	980	95	46	96	3145	3	69	560	7.5	107.48
EP-1120	1120	95	46	96	3375	3	78	640	10	122.84
EP-1260	1260	95	46	96	3591	3	88	720	10	138.19
EP-1400	1400	106	58	91	4360	3	98	800	12	153.55
EP-1540	1540	106	58	102	4711	4	108	880	12	168.9
EP-1680	1680	106	58	102	4927	4	118	960	15	184.26
EP-1820	1820	106	58	102	5197	4	127	1040	15	199.61
EP-1960	1960	106	58	102	5414	4	137	1120	15	214.97
EP-2100	2100	116	62	109	5994	4	147	1200	24	230.32
EP-2380	2380	116	62	109	6210	4	167	1360	24	261.03
EP-2520	2520	135	48	109	6831	6	176	1440	24	276.39
EP-2660	2660	135	48	109	7047	6	186	1520	24	291.74
EP-2800	2800	135	48	109	7304	6	196	1600	24	307.1
EP-2940	2940	135	48	109	7519	6	206	1680	24	322.45
EP-3080	3080	135	48	109	7735	6	216	1760	24	337.81
EP-3220	3220	135	48	109	8073	6	225	1840	24	353.16
EP-3360	3360	135	48	109	8168	6	235	1920	30	368.52
EP-3500	3500	152	55	105	13200	6	245	2020	30	383.87
EP-4000	4000	152	55	105	14400	6	280	2310	30	438.71
EP-4500	4500	170	60	103	15600	6	315	2600	40	493.55
EP-5000	5000	170	60	103	16800	6	350	2890	40	548.39
EP-5500	5500	170	60	105	18000	6	385	3180	40	603.23
EP-6000	6000	178	72	107	19200	6	420	3470	50	658.07
EP-6500	6500	178	72	107	20400	6	455	3760	50	712.9
EP-7000	7000	185	72	112	21600	6	490	4050	60	767.74
EP-7500	7500	185	72	112	22800	8	525	4340	60	822.58
EP-8000	8000	185	72	112	24000	8	560	4630	60	877.42
EP-8500	8500	185	72	127	25200	8	595	4910	75	932.26
EP-9000	9000	216	79	118	26400	8	630	5200	75	987.1
EP-9500	9500	216	79	118	27600	8	665	5500	75	1041.94
EP-10000	10000	246	86	135	28800	8	700	5780	75	1096.78

*Sahara reserves the right to make changes without notification. Some models not shown. Other sizes and pressures available.
Metric dimensions available upon request. Ratings are based on 100 PSIG, 100°F.*



World Leader in Regenerative Dryer Technology



Henderson Engineering Co.
815.786.9471 800.544.4379



**One of the
world's largest
heat-of-compression
installations;
operating at nearly
zero cost.**

Sahara Air Products

A Div. of Henderson Engineering Co., Inc.
95 North Main Street
Sandwich IL 60548
800-544-4379 • 815-786-9471
Fax 815-786-6117
www.saharahenderson.com



*Henderson Engineering Co., Inc., is proud to be certified to the
ISO 9001 Quality Management System standards and guidelines*