

Sahara HP

Deliquescent Air Dryer



Henderson Engineering Co.
815.786.9471 800.544.4379

The only
COMPLETE
Deliquescent
Air Treatment System
available for
drying compressed air



World Leader in Regenerative Dryer Technology





World Leader in Regenerative Dryer Technology



Henderson Engineering Co.
815.786.9471 800.544.4379

You Have A Problem...

Wherever compressed air is used, there is danger of damage to equipment; freezing of lines, unnecessary rejects, contamination or dilution of products, and a distinct probability of breakdowns due to cylinder, valve or gauging failure. This is because harmful materials contained in all free air, such as moisture, dust, mildly corrosive gases and bacteria, are drawn into the compressor and compressed with the air, making them concentrate as much as twelve times more densely. Also, when air is compressed, its temperature becomes high enough to vaporize lubricants in the compressor itself; worn piston rings commonly deliver large amounts of oil fumes with each stroke. This high temperature allows the dense moisture, oil, and other contaminants to travel with the air.

Unfortunately, as the air leaves the compressor, its temperature begins to drop causing these contaminants to condense in the lines, forming mixtures more corrosive than water alone. As the temperature drops from one point of the system to the next, more water, oil, dirt, etc. condenses. This corrosive solution gathers in low spots causing corrosion of the pipes, freezing, and line chatter that loosens the rust and scale in the pipes. Oil is beneficial to tools and, for this reason, there are lubricators in the line to deliver metered flows of lubricating air to them. The oil used is a light machine oil, but the oil from the compressor condenses into a heavy, gummy "oil varnish".

This sticky residue collects dirt and builds up on the spools of packless valves causing them to stick. It coats the inside of air gauges causing these expensive tools to give false readings. It gathers in cylinders causing "stiction" and seizing, and it robs air tools of their power by building up on turbines, moving parts, etc. Neither water, nor oil, can be tolerated where product purity is desired.

Old methods of removal such as separators, traps, filters, droplegs, etc., have proven ineffective, because they merely stop a percentage of the entrained liquids and the larger particles of rust and scale...the vapors escape them to condense further on. The cost of these ineffective methods is high; many filters must be checked, cleaned and replaced, all the droplegs and separators blown down, tools must be cleaned and repaired...every day! In the winter, crews must take blowtorches to free frozen air lines, since a sudden drop in pipe temperature causes extreme condensation. The greatest waste involved with this system is that it doesn't do the job. These old methods can't protect you like one super filter-dryer installed near the compressor can. Water, oil, dirt, and other contaminants are responsible for costly rejects, reworks, freeze-ups, breakdowns, and have been proven to sap the power and shorten the life of air tools, components, and the compressed air system itself.

...We Have The Solution...

What A Sahara HP Air Dryer Will Do For You!

The addition of a Sahara air dryer purification system to the compressed air system will remove the causes of these production and maintenance problems at less cost than these problems generate. Installed directly after the receiver, a Sahara air dryer purification system will remove water and oil; as well as many small particles of dirt, rust and scale, and at a cost of 2% of the cost of compressing the air...or less! If only limited protection is desired, a small dryer can be installed directly before any point of use.

- Eliminate downtime and breakdowns due to corrosion of pipes, tools, components or damage to components and tools by rust, dirt or oil in air.
- Lower the dew point of compressed air to prevent downstream condensation, line chatter, and freeze-ups.
- Eliminate rejects due to product contamination or dilution, fouled paint jobs, or loss of precision from fouled gauging.
- Operate for less due to longer lasting dual action Mity-Dry.

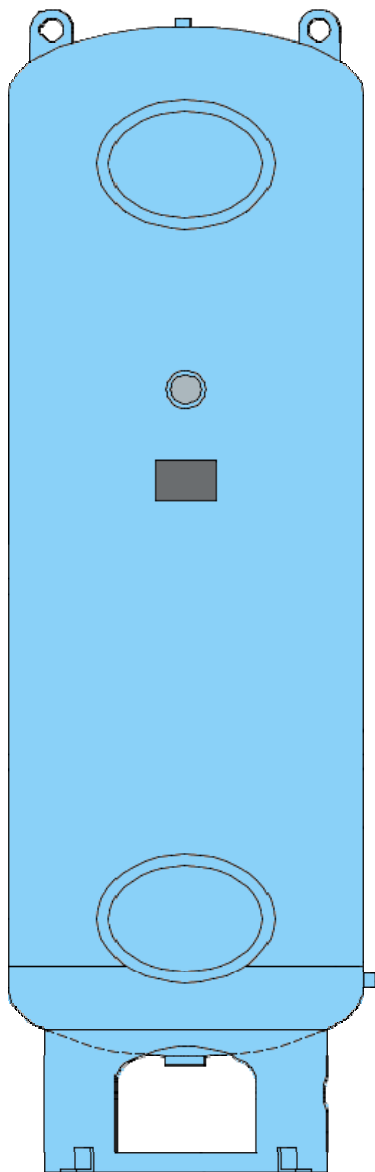

Low Maintenance Operation

A Sahara system will substantially reduce the maintenance required by tools, cylinders, valves, and gauges...cutting downtime to a minimum and allowing reduction of replacement parts stock. Properly located, a dryer will eliminate freeze-ups and breakdowns due to corrosive damage or oil varnish build-up. The dryer itself requires a minimum of maintenance. Addition of ultra hygroscopic Mity-Dry desiccant two or three times a year and daily draining is all that's required! A Sahara air dryer will eliminate the need for all routine upkeep on all the old water removal methods, droplegs, filters, separators, etc., you may own.



World Leader in Regenerative Dryer Technology



Henderson Engineering Co.
815.786.9471 800.544.4379

The Sahara System Cuts Cost Through Maximum Efficiency

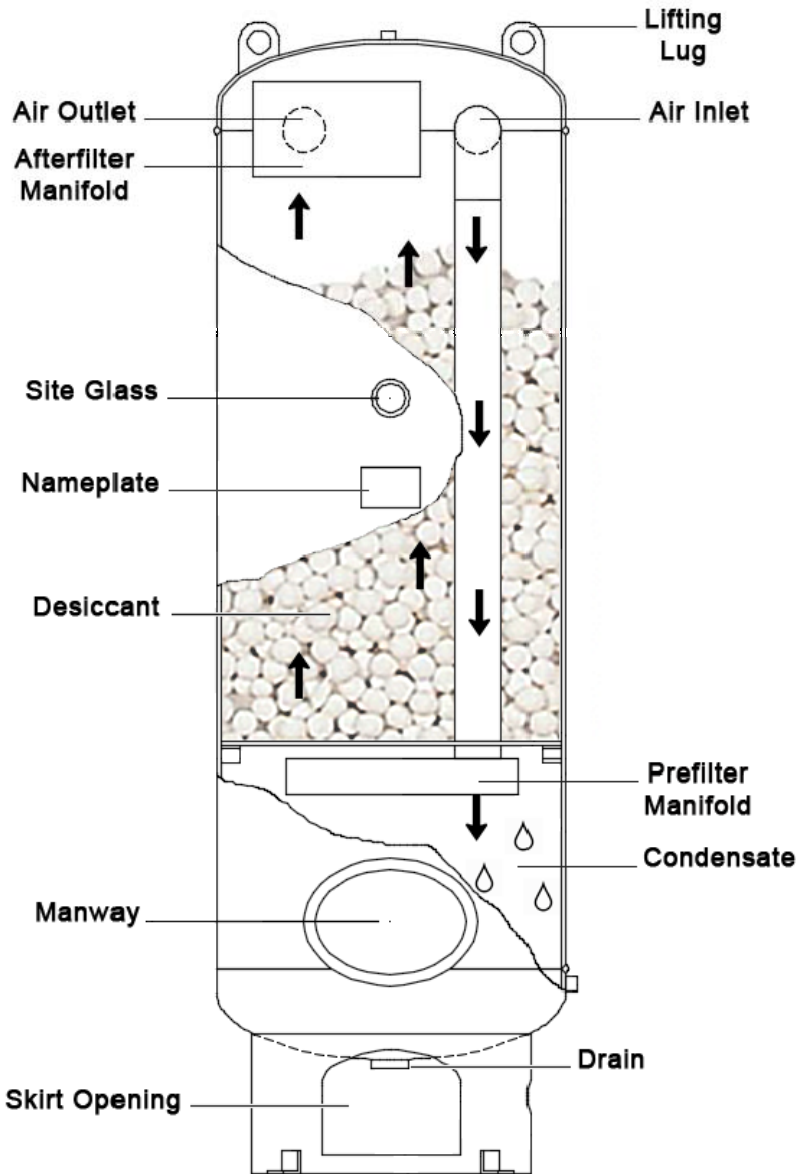

The basic Sahara HP air dryer is a welded steel pressure vessel constructed to ASME specifications, fully inspected, and hydrostatically pressure tested. Every vessel is registered with the National Board of Boiler and Pressure Vessel Inspectors. All dryers are protectively coated inside and out for long, dependable service. The interior surfaces are protected by a corrosion inhibitive primer and a tough epoxy finish coat. Interior coatings of polyurethane are available, if desired, but our experience shows epoxy to be a superior protective agent.

It is designed to force the compressed air to flow down to the bottom of the vessel, then up through a bed of Mity-Dry ultra hygroscopic desiccant. This 180° change of direction, coupled with the drop in velocity of the air, serves to lose the larger droplets of water, oil, and larger solids.

The system is designed with a greater desiccant capacity, so desiccant doesn't have to be replenished as often as with other dryers. The Mity-Dry desiccant is a patented polychemical ultra-hygroscopic agent. It is non-volatile and requires no regeneration. The moisture and oil combines with Mity-Dry to form a water, oil, desiccant solution that falls harmlessly to the bottom of the dryer and is drained away. The superb action of Mity-Dry combined with a Sahara prefilter will provide unexcelled, maximum protection. Mity-Dry is non-irritating to the skin. It has been granted approval for use in food, drug, beverage, and meat packing plants by the Food and Drug Administration and by the Meat Inspection Division of the Department of Agriculture.

Mity-Dry has two distinct advantages over other hygroscopic desiccants:

- 1) It lasts longer and is more effective due to more compact tablets formed at high pressures.
- 2) It contains special inhibitors to prevent rusting and pitting of iron pipes and tanks and prevents alkali corrosion of tin and aluminum.

A Long & Proud Company History



Sahara Air Products, a Division of Henderson Engineering Co., Inc., was founded in 1957 by Joe and Evelyn Henderson to provide engineered solutions for air system problems. Mr. Henderson's philosophy was to thoroughly examine the unique requirements of each customer and to develop the most economical and reliable system solution for that application. This trademark of engineered solutions exists at Sahara today, as the third generation of Hendersons continue the tradition of product excellence and customer service. Sahara's reputation for high quality, innovative products, and customer loyalty has continued to grow through the years.

As a family business, we know that our greatest assets are our employees. Most of our people have been with us for more than 20 years. There is no substitute for experience. Sahara employees are true team members who know what they're doing and they truly care about doing it right the first time. This means you get what you want; a drying system that delivers performance year after year, decade after decade.

Quality and old world craftsmanship never goes out of style

Worldwide Installations





World Leader in Regenerative Dryer Technology



Henderson Engineering Co.
815.786.9471 800.544.4379

HP Specifications & Dimensions

Model	A (in.)	B (in.)	C (in.)	D (in.)	E (in.)	F (in.)	G (in.)	Approx. Weight (Lbs.)
HP-25	6 5/8	36	26 1/4	-	4 1/16	3 x 4	3/4	59
HP-50	8 5/8	36	26 1/4	-	5 1/16	3 x 4	1	110
HP-90	10 3/4	55 1/2	42 1/4	6	5 7/8	6 x 8	1 1/2	150
HP-125	12 3/4	66	52 1/2	6	7	6 x 8	1 1/2	185
HP-215	16	76	61	8	8 1/2	6 x 8	1 1/2	315
HP-275	18	79	63 1/2	8	9 1/2	6 x 8	2	380
HP-400	22	94	87	10	14	8 x 10	3	775
HP-500	24	95	87 1/2	10	16	8 x 10	3	825
HP-750	30	98	89	15	19	11 x 15	4	1,300
HP-1100	36	102	91	15	22	11 x 15	4	1,550
HP-1500	42	104	92	15	25	12 x 16	4	1,890
HP-1900	48	108	94	22	28 1/2	12 x 16	6	2,525
HP-2400	54	112	96	22	31 1/2	12 x 16	6	3,420
HP-3000	60	115	97 1/2	22	34 1/2	12 x 16	6	3,920
HP-3700	66	118	100	22	37 1/2	12 x 16	6	4,445
HP-4500	72	121	102	32	41	12 x 16	8	5,095
HP-5200	78	126	104	32	45	12 x 16	8	6,270
HP-6000	84	129	106	32	48	12 x 16	8	6,920
HP-6800	90	132	107	32	51	12 x 16	8	8,250
HP-7800	96	135	108	41	54	12 x 16	10	9,380
HP-8800	102	138	109	41	57	12 x 16	10	10,200
HP-10000	108	141	111	41	60	12 x 16	10	11,080
HP-11000	114	143 1/2	112	41	63	12 x 16	10	12,970
HP-12000	120	148	115	41	66	12 x 16	10	16,400
HP-13500	126	150	116	41	69	12 x 16	10	17,625
HP-14500	132	152	117	41	73	12 x 16	10	18,895
HP-16000	138	156	118	48	75	12 x 16	12	21,585
HP-17500	152	162	121	48	81	12 x 16	12	29,200
HP-20000	158	165	123	60	84	12 x 16	14	31,000
HP-25000	168	170	125	72	90	12 x 16	16	34,000

*Sahara reserves the right to make changes without notification. Some models not shown. Other sizes and pressures available.
Metric dimensions available upon request.*

Sahara HP Deliquescent Air Dryer

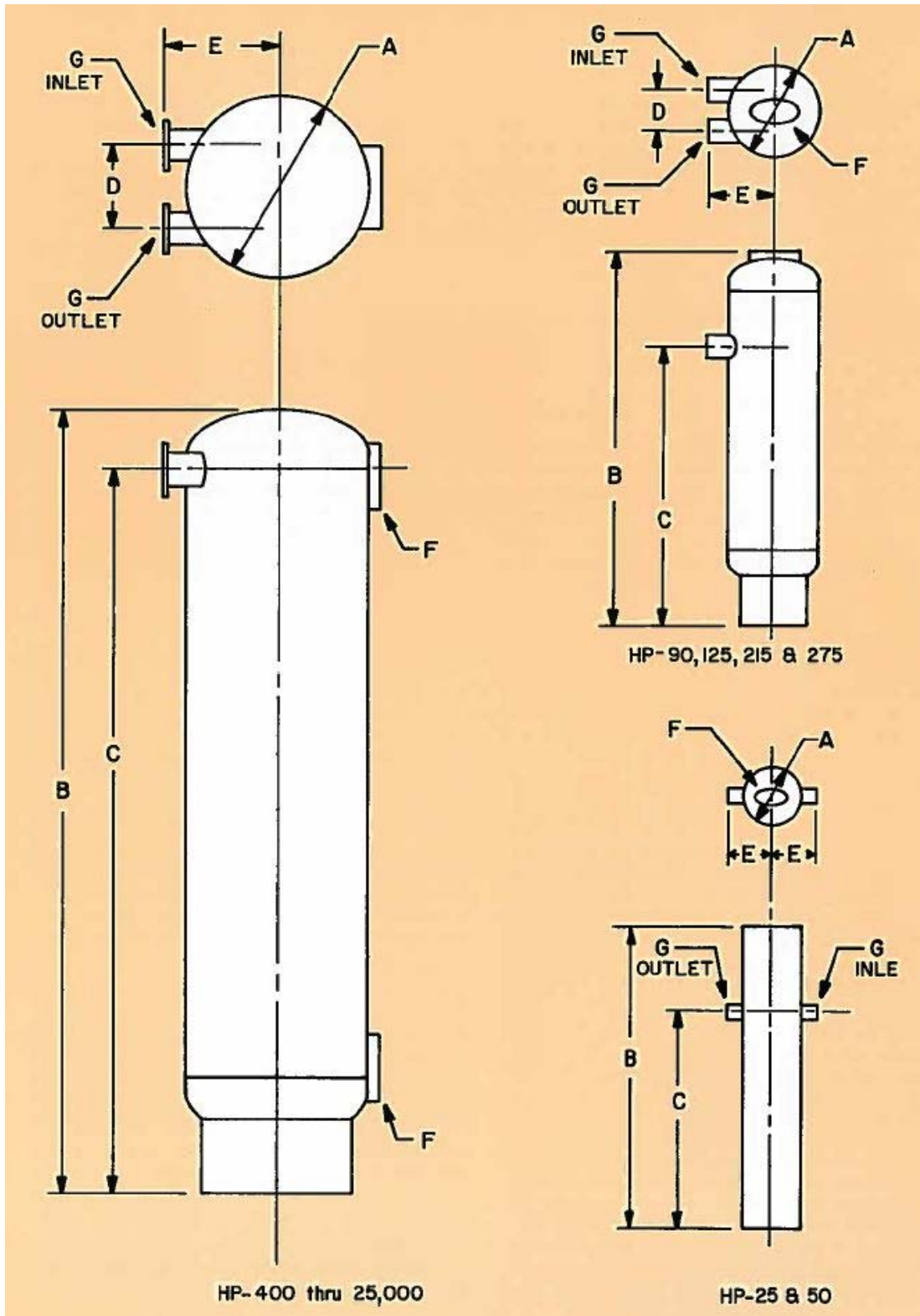

We can build a dryer to meet your strict performance requirements



World Leader in Regenerative Dryer Technology



Henderson Engineering Co.
815.786.9471 800.544.4379

HP Air Dryer Capacities

Always size a dryer to your toughest requirements. It's better to have a dryer oversized that does a good job than to have a dryer too small that cannot give the desired results. The sizing requirements should be figured during a peak use period and future expansion of compressed air should be considered. The absolute lowest gauge pressure (at the point where the dryer is located) and the absolute highest SCFM are used to determine the size dryer required.

For example: If you have 525 standard cubic feet of air minute at a lowest pressure of 80 PSIG, reference the 80 PSIG column below to find a dryer that will handle 525 SCFM. The dryer you would need is the HP-750. A dryer sized for your most difficult requirements will give superior service during your average work periods and deliver safe, desert dryer air for your most hectic demanding periods.

Model	MAX. RATED PSIG	SCFM @ 30 PSIG	SCFM @ 40 PSIG	SCFM @ 50 PSIG	SCFM @ 60 PSIG	SCFM @ 70 PSIG	SCFM @ 80 PSIG	SCFM @ 90 PSIG	SCFM @ 100 PSIG	SCFM @ 125 PSIG	SCFM @ 150 PSIG	SCFM @ 200 PSIG
HP-10	200	4	4	5	6	7	8	9	10	12	14	18
HP-25	200	10	12	14	16	18	21	23	25	30	36	45
HP-50	200	19	24	28	32	37	41	46	50	60	72	90
HP-90	200	35	43	51	59	67	74	82	90	110	129	168
HP-125	200	49	60	71	82	92	103	114	125	152	179	234
HP-215	200	84	103	122	140	159	178	196	215	262	308	402
HP-275	200	107	132	155	179	203	227	251	275	335	395	514
HP-400	150	155	190	220	260	294	330	365	400	484	576	
HP-500	150	194	240	280	324	368	412	456	500	600	720	
HP-750	125	290	360	410	490	550	620	684	750	900		
HP-1100	125	430	520	600	710	810	910	1000	1100	1330		
HP-1500	125	580	700	830	970	1100	1240	1370	1500	1810		
HP-1900	125	740	900	1050	1230	1400	1570	1730	1900	2300		
HP-2400	125	930	1140	1330	1550	1760	1980	2190	2400	2900		
HP-3000	125	1160	1420	1660	1940	2205	2475	2740	3000	3600		
HP-3700	125	1440	1750	2050	2400	2720	3050	3370	3700	4500		
HP-4500	125	1750	2130	2500	2920	3300	3710	4100	4500	5450		
HP-5200	125	2020	2460	2880	3370	3800	4290	4740	5200	6300		
HP-6000	125	2330	2840	3330	3890	4400	4950	5470	6000	7260		
HP-6800	125	2640	3220	3770	4400	5000	5610	6200	6800	8230		
HP-7800	125	3030	3700	4320	5050	5730	6435	7110	7800	9440		
HP-8800	125	3410	4170	4880	5700	6470	7260	8030	8800	10650		
HP-10000	125	3880	4740	5550	6480	7350	8250	9120	10000	12100		
HP-11000	125	4270	5200	6100	7130	8085	9075	10030	11000	13300		
HP-12000	125	4660	5690	6650	7780	8820	9900	10940	12000	14500		
HP-13500	125	5240	6400	7490	8750	9920	11140	12310	13500	15300		
HP-14500	125	5630	6870	8040	9400	10650	11960	13220	14500	17550		
HP-16000	125	6200	7580	8870	10370	11760	13200	14590	16000	19360		
HP-17500	125	6800	8300	9700	11340	12860	14440	15960	17500	21180		
HP-20000	125	7760	9480	11090	12960	14700	16500	18240	20000	24200		
HP-25000	125	9700	11850	13860	16200	18380	20630	22800	25000	30250		

Ratings are based on 100 PSIG, 100°F.

The dryer must be located in the coolest area possible with the temperature of the air entering the dryer NO HIGHER THAN 100°F. Install the dryer outside with a receiver before it for best results. A dryer installed outside will compensate for sudden changes in temperature and will use less desiccant for more economical operation. Always provide shade for a dryer outside. For assistance in sizing a dryer to meet your performance requirements, contact one of our Sales Engineers.

Sahara Air Products

A Div. of Henderson Engineering Co., Inc.
95 North Main Street
Sandwich IL 60548
800-544-4379 • 815-786-9471
Fax 815-786-6117
www.saharahenderson.com



Henderson Engineering Co., Inc., is proud to be certified to the ISO 9001 Quality Management System standards and guidelines