

T Heatless

Regenerative Compressed Air Dryer

No CFC's

No condensate disposal



Henderson Engineering Co.
815.786.9471 800.544.4379

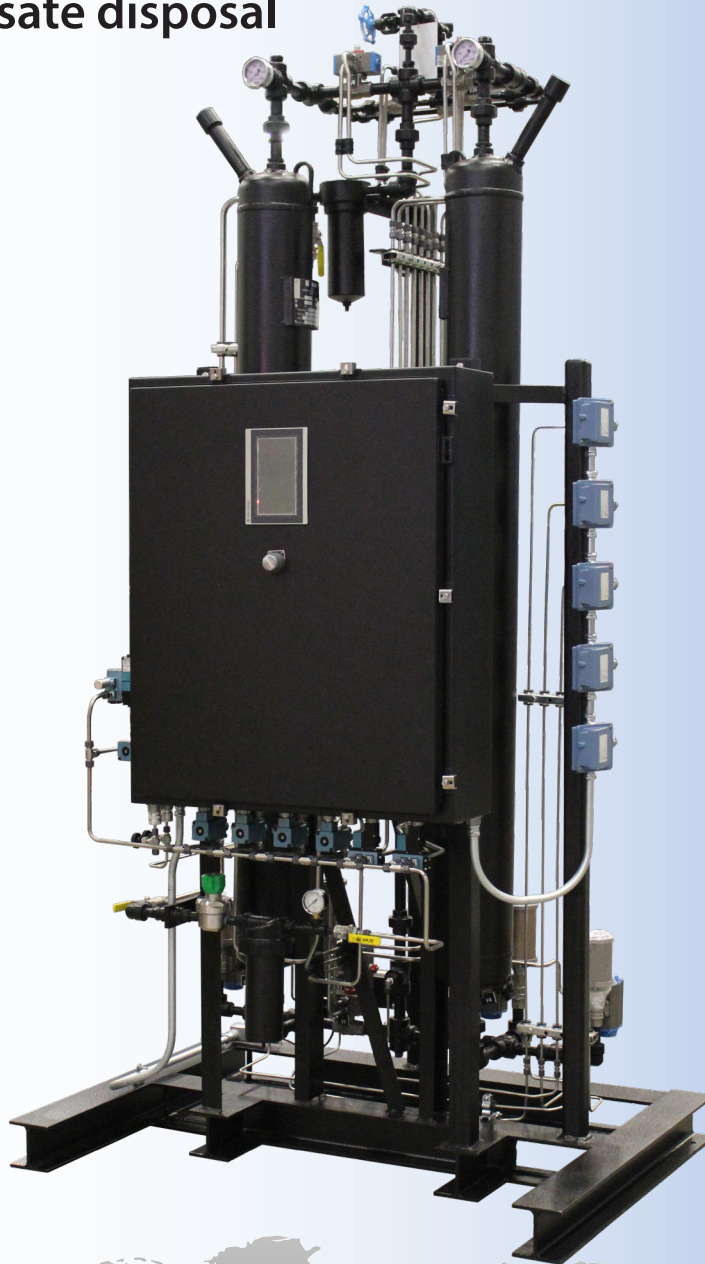

World Leader in Regenerative Dryer Technology





World Leader in Regenerative Dryer Technology



Henderson Engineering Co.
815.786.9471 800.544.4379

A Long & Proud Company History



Sahara Air Products, a Division of Henderson Engineering Co., Inc., was founded in 1957 by Joe and Evelyn Henderson to provide engineered solutions for air system problems. Mr. Henderson's philosophy was to thoroughly examine the unique requirements of each customer and to develop the most economical and reliable system solution for that application. This trademark of engineered solutions exists at Sahara today, as the third generation of Hendersons continue the tradition of product excellence and customer service. Sahara's reputation for high quality, innovative products, and customer loyalty has continued to grow through the years.

As a family business, we know that our greatest assets are our employees. Most of our people have been with us for more than 20 years. There is no substitute for experience. Sahara employees are true team members who know what they're doing and they truly care about doing it right the first time. This means you get what you want; a drying system that delivers performance year after year, decade after decade.

Quality and old world craftsmanship never goes out of style

Worldwide Installations



Custom Design

Dryers are purchased to solve plant air problems. The decision to buy is complex and involves many variables; initial price, vendor qualifications, delivery, performance, and operating cost, just to name a few. The selection of a SAHARA air dryer is a safe choice. Our sales engineers will help you select the right system for your application. They have the expertise to review your plant air system and design the optimum engineered solution.

Need your documentation and instruction manuals in your native language? Require instrumentation in dual scale? With Sahara's experience in designing and building our products for customers worldwide, we can provide that for you.

Applications

- We make dryers for instrument air, as well as a variety of special applications
- High pressure up to 5000 PSIG / 345 Bar(g)
- Low pressure down to 20 PSIG / 1.4 Bar(g) for ozone generators that deliver constant, flat line, not to exceed -100°F / -73°C dew points
- Gases other than air; N₂, CO₂, CH₄
- We build dryers to API specifications
- We also make dryers for air separation companies
- Capable of delivering extremely low dew points
- Used in automotive paint applications or electronics where air is used to blanket chips and for any critical uses that demand dry air

**We can build a dryer to meet your strict performance requirements
Contact us and our sales engineers will help you select
the right system for your application.**

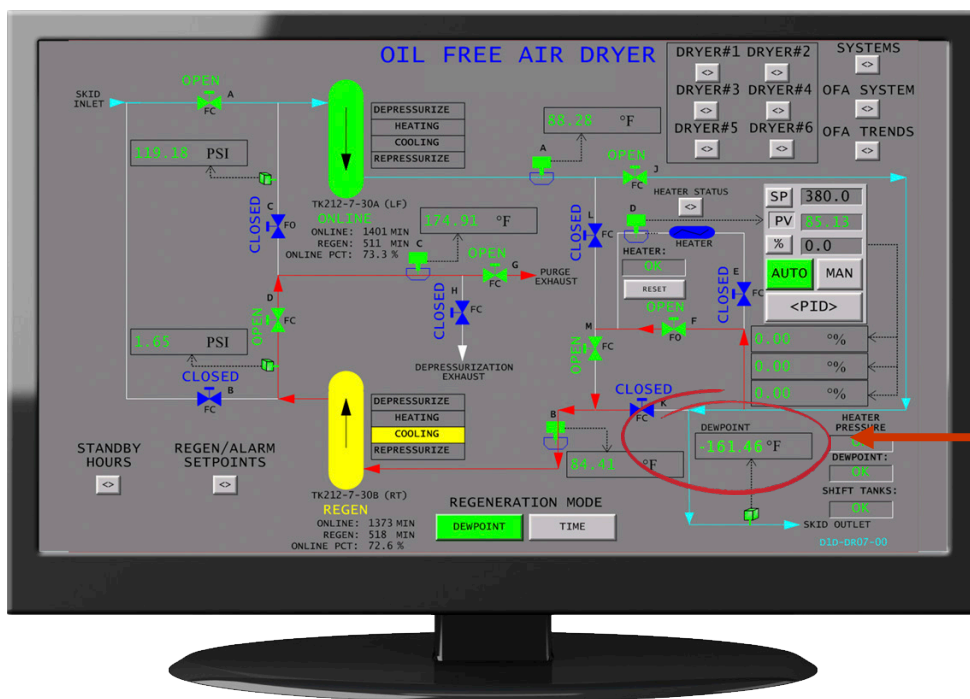

-161.46 PDP
at one of our
electronics
customer's facilities

**Quality and reliability are built into every SAHARA air dryer
and performance is guaranteed**



World Leader in Regenerative Dryer Technology



Henderson Engineering Co.
815.786.9471 800.544.4379

Real World Performance

SAHARA's T Heatless regenerative air dryer is the most reliable dryer ever built. Since this unit requires neither heaters nor blowers, it is inherently more trouble-free than any heat-reactivated dryer.

Gravity is a powerful force and the T Heatless dryer has been specifically designed to fully utilize the force of gravity to optimize dryer performance. With a wet air inlet at the bottom of the dryer, water and oil droplets are concentrated at the bottom of the desiccant bed. During downflow depressurization and regeneration, the power of gravity helps pull the water and oil out of the dryer.



Upflow Drying/Packed Bed

In the real world, air demand fluctuates. Sometimes compressors are turned off on Friday. Over the weekend, your air system loses pressure. Turn on the compressors Monday morning and the velocity through a dryer is high enough to pulverize the desiccant. Competitors tell you to slowly pressurize the system to avoid desiccant fluidization. Right.

At SAHARA, we designed the T Heatless to operate in the real world. Packed desiccant beds allow the T to operate at 0 to 100% flow; full line pressure or no line pressure. You don't have a problem downstream with a SAHARA T Heatless.

Mufflers

Heatless dryers are by nature noisy. Every few minutes, the valves shift and one tower depressurizes. There's no way you can disguise this blast of air. We understand the concern about noise levels in the workplace and provide mufflers that are specifically designed for dryer service. In the real world, mufflers eventually get clogged up with desiccant dust, reducing the efficiency of the dryer. The T Heatless air dryer is equipped with a failure-to-depressurize alarm that will alert you to change your mufflers and/or check for valve leakage. You get better performance and a quieter environment.

Peace of Mind

In the real world, nothing works forever and nothing lasts forever. The T Heatless air dryer comes pretty close. While we can't promise that nothing will ever fail, we will work together to keep your plant air system up and running. At SAHARA we understand that our business relationship is a partnership. Minimum downtime, minimum cost, for maximum benefits. Giving you peace of mind. We know your time is valuable; spend it with your family, not servicing a dryer.

INTEGRAL COMPONENTS

Switching valves are 2-way diaphragm actuated globe valves up to 2" and high performance individually actuated butterfly valves which provide bubble-tight shut-off for optimum efficiency for 3" and larger line sizes.

Purge flow for regeneration is controlled by a pre-set fixed orifice, allowing precise measurement of the purge flow.

An electronic, adjustable controller provides for reliable tower switching.

If power failure should occur on ANY of our dryer units, the offline tower will repressurize and the online tower will continue to dry full flow air. Our units, unlike many competitors' dryers, DO NOT BLOW DOWN and stop the drying cycle in the event of power failure.

The unique design of our pressure vessels prevents desiccant fluidization in normal or upset conditions. Optimum design of a heatless dryer has downflow regeneration. We all know that gravity is a powerful force. Our Heatless dryers use the power of gravity to optimize purge air loss and assist in depressurization and regeneration. Some other dryer manufacturers don't use downflow regeneration because their vessel design allows fluidization during the drying process. Our unique standpipe packed bed design prevents fluidization during normal operation, as well as under upset conditions. We provide a completely packed bed so there's nowhere for desiccant to go. As the desiccant ages over time, the additional volume in the standpipe keeps the tower completely full and packed. Doing little things like this makes the entire system more reliable and efficient.

A particulate afterfilter is provided as a standard, integral part of the dryer system (through Model T-75). Pilot air is tapped off of the outlet side of this filter to provide clean control air. The Model T-100 and larger are equipped with a pilot air filter to provide clean control air.

Each dryer is factory tested and is ready for installation.



STANDARD FEATURES

- Eliminates costly installation charges; all components are pre-piped and pre-wired
- Minimizes potential for wear and mechanical failure
- Lower initial cost than other regenerative dryer designs
- Available in capacities from 7 SCFM to 12,000 SCFM
- Design delivers pressure dew points from -40 °F to -100 °F, depending on your operating conditions and requirements
- Reduced noise level; dryer meets OSHA noise regulations with weighted average of 85 dBA
- NEMA 4 electrical construction (indoor)
- Low pressure drop; excess pressure drop costs money. We design our complete system to keep pressure drop low.
- PLC operation



World Leader in Regenerative Dryer Technology



Henderson Engineering Co.
815.786.9471 800.544.4379

Quality Components & Features Included

SWITCHING VALVES



- Rated bubble-tight shutoff
- Directs air to the drying tower
- Standard butterfly valve actuation is good for 0°F to 225°F (-17.78°C to 107.22°C) ambient temperatures. Lower temperatures available.
- 2" & smaller: Diaphragm actuated globe valves with position indicator
- 3" & larger: Reliable 2-way non-lubricated high performance butterfly valves w/SS internals and reinforced fire safe teflon seat

CHECK VALVES



- 2" & smaller: Spring loaded ball cone style allows for fast sealing; bronze body, glass filled TFE ball with a 316 SS spring
- 3" & larger: Double door spring; cast iron body with aluminum internals, wafer with silicone seal, and 304 SS springs
- Bubble tight shutoff; no radial alignment required
- Straight through design streamlined for minimum change in velocity and minimizes pressure drop

DEPRESSURIZATION MUFFLERS



- Utilized on the blowdown, keeps noise levels to a minimum
- Complies with OSHA standards by keeping noise tolerance at <85 dBA on a time-weighted average

ELECTRICAL



- Standard electrical construction in a NEMA 4 enclosure (indoor)
- Other NEMA classes available
- UL fabricated panels available
- 4-minute or 8-minute time cycle
- Built to latest NEC Guidelines

SEPARATE PILOT AIR FILTER



- With pressure gauge and block valve to protect dryer control system (T-100 and larger)

PRESSURE SWITCH



- Low system pressure alarm helps to protect system from overloading
- Failure to depressurize alarm to warn user of potential valve failure

Controller Comes Standard

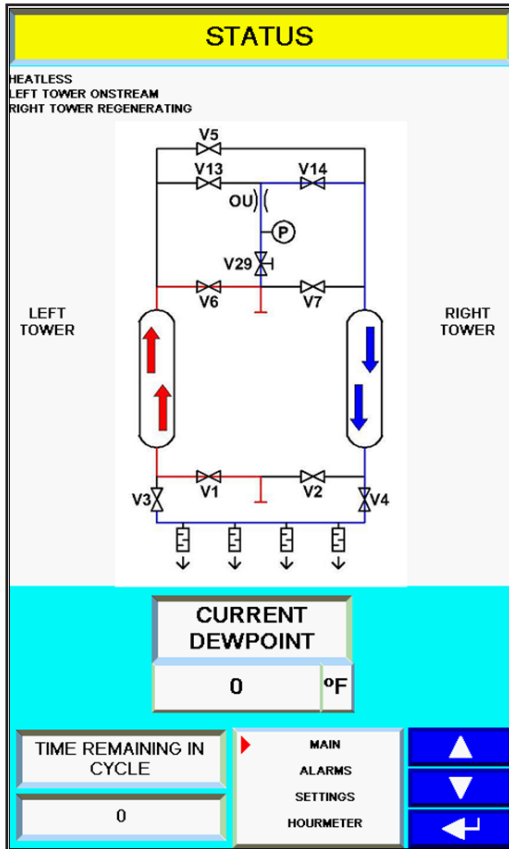

- The standard PLC controls the dryer's operation
- Ethernet communication
- The standard operator interface for local control of the air dryer
- Housed in a NEMA 4 enclosure, the operator interface uses a touch sensitive screen with control functions performed by touching on-screen display buttons to change screens, modify settings, or enter values
- Dryer cycle indication
- P&ID for each cycle on operator interface screen

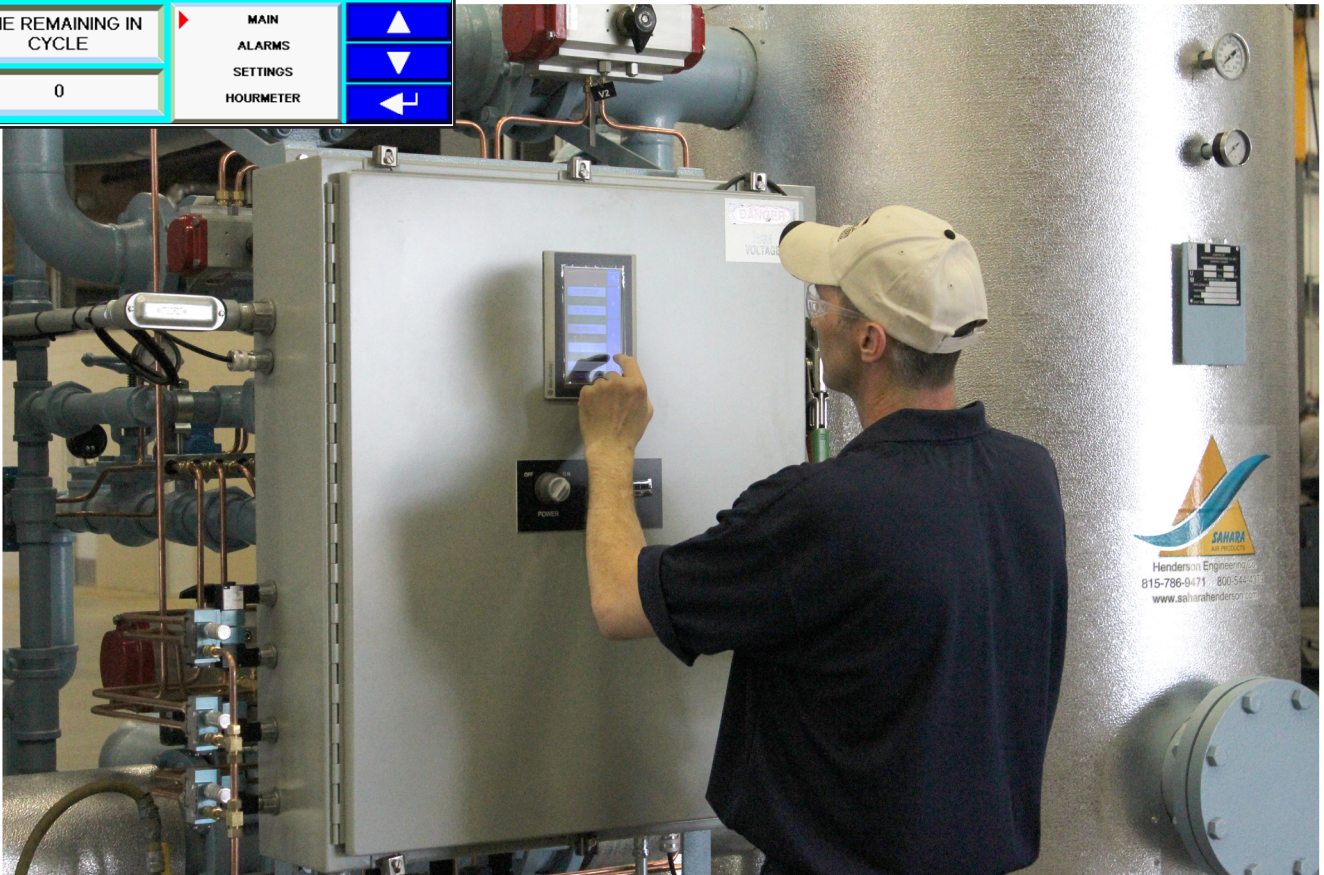



World Leader in Regenerative Dryer Technology



Henderson Engineering Co.
815.786.9471 800.544.4379

Standard Options

SAHARA DEW POINT DEMAND SYSTEM

Energy conservation has always been a strong design consideration of Sahara Air Products. The Dew Point Demand System measures the dew point of the outlet air, overriding the timer, eliminating unnecessary switching of towers resulting in considerable savings through reduction of regeneration cost. Additional savings can be realized with this system by reducing wear on component parts, as well as extending the life of desiccant.

The SAHARA Dew Point Demand System utilizes a state-of-the-art moisture transmitter to accurately measure the actual PRESSURE DEW POINT the dryer is delivering at all times. The instrument reads directly to the PLC and is displayed on the Panel View screen, which constantly keeps you informed of dryer performance. An adjustable set point allows you to set the precise dew point for tower switching. Tower switching can be activated anywhere within the broad range of -148°F to +86°F (-100°C to 30°C).

UPGRADE CHECK VALVES TO ACTUATED SWITCHING VALVES

- Reliable 2-way
- Rated bubble-tight shutoff
- Non-lubricated
- Fire safe
- Standard butterfly valve actuation is good for 0°F to 225°F (-17.78°C to 107.22°C) ambient temperatures. For lower temperatures, consult Henderson Engineering.
- 2" & smaller: Rack & pinion actuated ball valves with bronze internals & reinforced teflon seat
- 3" & larger: high performance butterfly valves with stainless steel internals & reinforced teflon seat

MOISTURE INDICATOR

Visual indication of outlet air moisture content by means of color change media.

INDIVIDUAL VALVE FAILURE ALARM

Each valve is equipped with a limit switch to activate an alarm light on the control panel indicating individual valve failure.

COALESCING PREFILTER

For optimum performance of a regenerative dryer application, we recommend a prefilter upstream of the dryer to protect the desiccant bed from contamination by oil, entrained water, or other contaminants. For this duty, we offer a Sahara high efficiency oil coalescing prefilter (HEF). This unit is constructed of carbon steel to ASME standards and is designed to filter oil to 1 PPM and dirt particles to 0.3 micron with a 75 PSIG differential collapse pressure.

PARTICULATE AFTERFILTER

We recommend a particulate afterfilter downstream of the dryer to eliminate the possibility of desiccant dust carryover into the air system. For this duty, we offer a Sahara particulate afterfilter. This unit is constructed of carbon steel to ASME standards and the elements are designed to filter particles to 1 micron.

FILTER MOUNTING

Filters may be mounted on dryer skid for ease of installation.

NEMA 7 ELECTRICAL CONSTRUCTION

ISOLATION & BYPASS PIPING

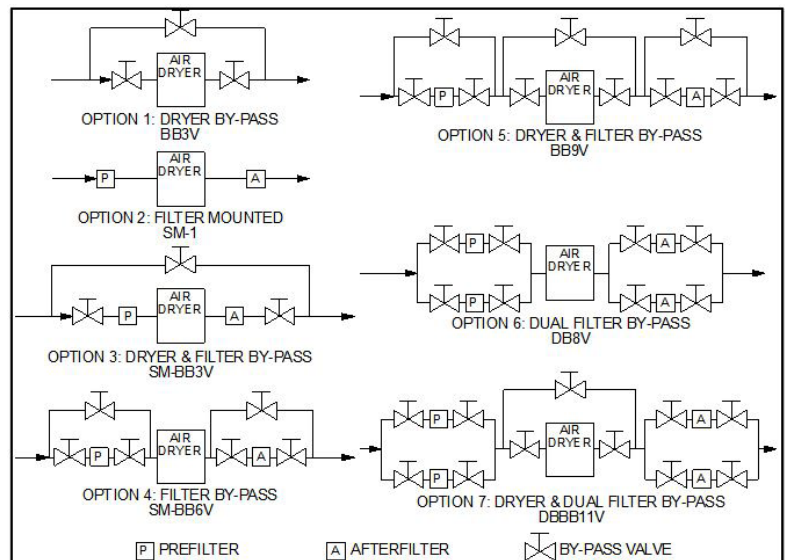

Theory of Operation

Wet compressed air enters the dryer at the bottom and is directed by non-lubricated switching valves into the drying tower. The wet air encounters dry desiccant and moisture is transferred from the air to the desiccant. The direction of air flow during drying is upflow; design of the towers prevents fluidization of the desiccant.

At the top of the dryer, the dry process air is directed to the outlet of the dryer through check valves. Approximately 15% of the dry air is directed into the regenerating tower where it is depressurized to atmospheric pressure and is used to regenerate the desiccant. After removing moisture from the desiccant, the purge air exits the dryer through a muffler and is blown out to atmosphere.

After a preset time, or based on the optional Dew Point Demand System, the dryer will shift towers. At tower shift, the regenerating tower is gradually repressurized, the switching valves shift and the offstream tower is depressurized.

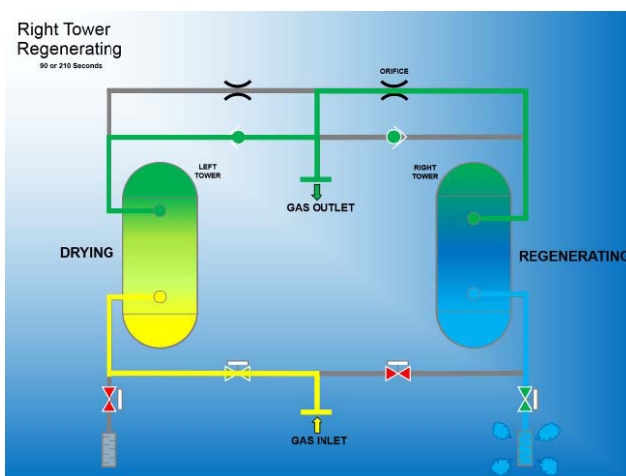

Illustration: T-150 & Smaller Heatless Dryer Flow Schematic

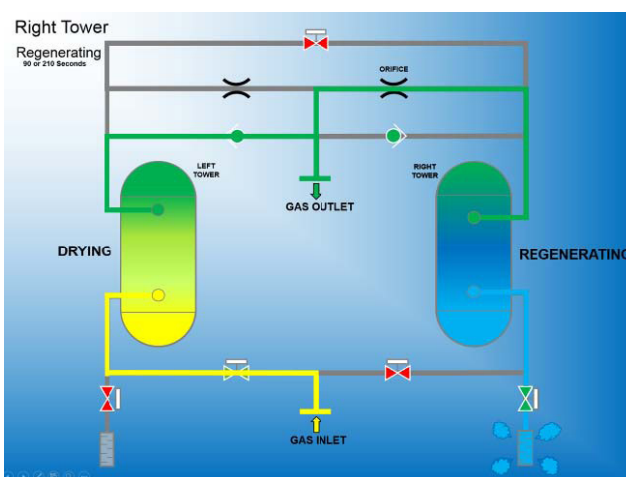

Illustration: T-200 & Larger Heatless Dryer Flow Schematic



World Leader in Regenerative Dryer Technology



Henderson Engineering Co.
815.786.9471 800.544.4379

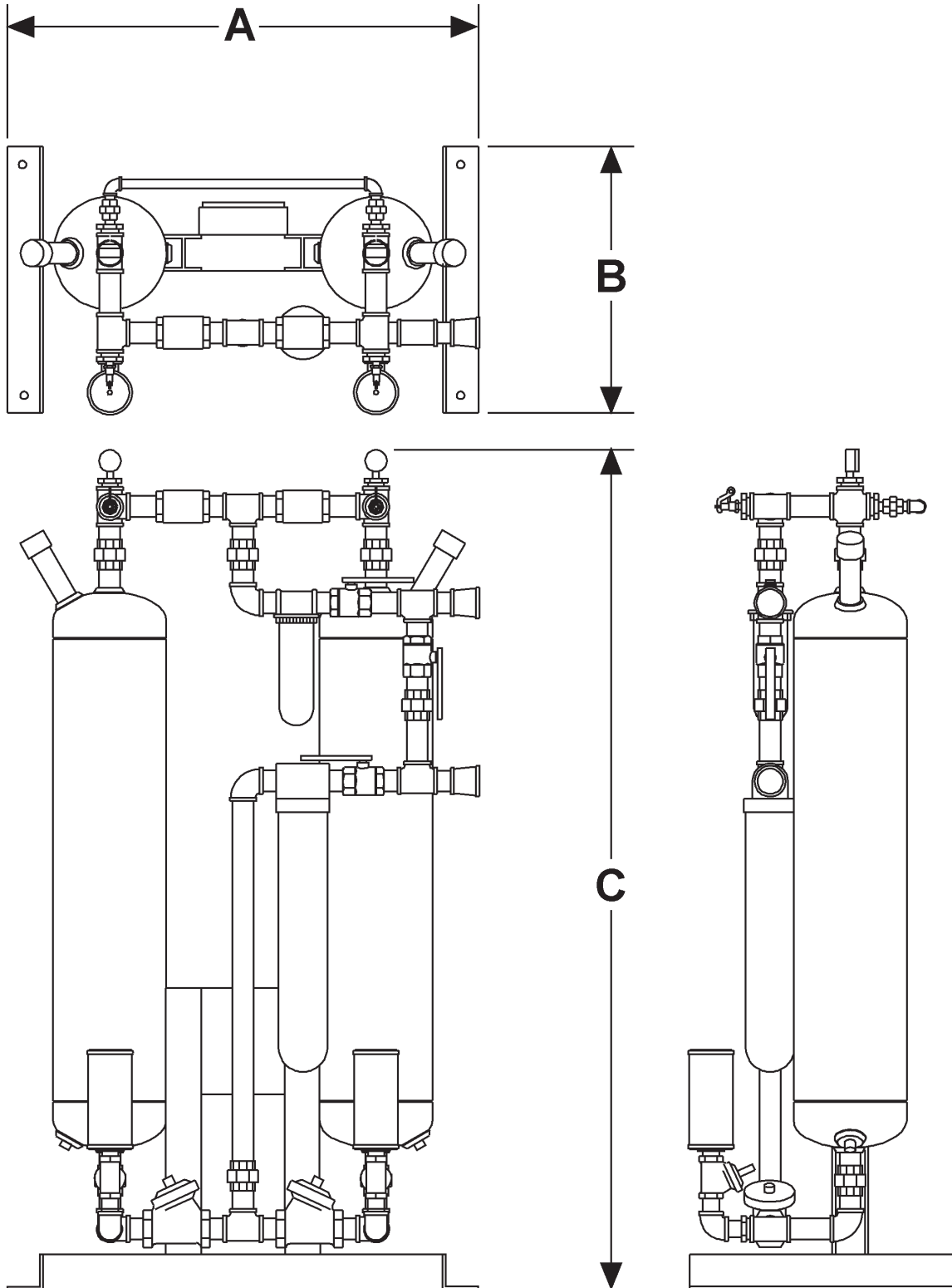

T Heatless Regenerative Compressed Air Dryer

MODEL	FLOW RATE	PURGE FLOW RATE	LINE SIZE	TOWER DIAMETER	LBS. DESSICANT/TOWER	LENGTH (INCHES)	WIDTH (INCHES)	HEIGHT (INCHES)	WEIGHT (POUNDS)
T-2	9	1.4	1/4"	4	5.4	27	23	53	125
T-5	23	3.4	1/4"	4	13.5	27	23	70	160
T-10	45	6.8	1/2"	5	30	30	32	82	255
T-15	68	10.1	3/4"	6	40.5	30	34	87	365
T-20	90	13.5	3/4"	6	54	39	34	103	475
T-25	113	16.9	1"	8.625	67.5	43	38	80	575
T-30	135	20.3	1"	8.625	81	43	38	89	1220
T-40	180	27	1 1/2"	10.75	108	46	42	84	1310
T-50	225	33.8	1 1/2"	10.75	135	46	42	95	1490
T-75	338	50.6	2"	12.75	202.5	60	40	96	1715
T-100	450	67.5	2"	14	270	62	42	104	2250
T-125	563	84.4	2"	16	337.5	66	45	101	2890
T-150	675	101.3	2"	18	405	66	48	98	3030
T-200	900	135	3"	20	540	64	49	108	3935
T-250	1125	168.8	3"	24	675	68	52	96	4420
T-300	1350	202.5	3"	24	810	68	52	111	4635
T-350	1575	236.3	3"	30	945	80	56	94	5120
T-400	1800	270	3"	30	1080	80	56	101	5485
T-500	2250	337.5	4"	30	1350	86	58	125	6220
T-600	2700	405	4"	36	1620	88	62	110	6930
T-700	3150	472.5	4"	36	1890	88	62	120	7650
T-800	3600	540	4"	42	2160	118	78	118	9695
T-900	4050	607.5	6"	42	2430	120	80	125	11,625
T-1000	4500	675	6"	42	2700	120	84	131	12,345
T-1200	5400	810	6"	48	3240	126	80	130	13,940
T-1250	5625	843.8	6"	48	3375	126	80	136	14,410
T-1400	6300	945	6"	54	3780	Consult Henderson Engineering Co., Inc. 815-786-9471			
T-1600	7200	1080	6"	54	4320				
T-1800	8100	1215	8"	60	4860				
T-2000	9000	1350	8"	60	5400				
T-2200	9900	1485	8"	66	5940				
T-2400	10800	1620	10"	66	6480				
T-2600	11700	1755	10"	66	7020				
T-2800	12600	1890	10"	72	7560				

Sahara reserves the right to make changes without notification. Some models not shown. Larger sizes available. Other pressures available. Metric dimensions available upon request. Ratings are based on 100 PSIG, 100°F.



World Leader in Regenerative Dryer Technology



Henderson Engineering Co.
815.786.9471 800.544.4379



One of the world's largest heat-of-compression installations; operating at nearly zero cost.

Sahara Air Products

A Div. of Henderson Engineering Co., Inc.
95 North Main Street
Sandwich IL 60548
800-544-4379 • 815-786-9471
Fax 815-786-6117
www.saharahenderson.com



Henderson Engineering Co., Inc. is proud to be certified to the ISO 9001 Quality Management System standards and guidelines